



HISTORY

To mark the 100th anniversary of Hans J. Wegner's birth in 2014, Carl Hansen & Søn is launching Wegner's CH88 chair - a 1955 design that has, to date, existed only as a prototype.

A CH88 prototype was first unveiled in 1955 at the international H55 Exhibition in Helsingborg, organized by the Swedish Design Association, Föreningen Svensk Form.

DESCRIPTION

The upper structure of the CH88 features a steam-bent wooden backrest for back support, with slight curvatures of the backrest's ends provides a natural resting place for the arms.

The steel frame, with straight back legs, supports an oval-shaped wooden seat - which is available with optional leather or textile upholstery.

The CH88 is available in beech, oak and smoked oak in a range of finishes and colors.

The frame is available in stainless steel, black powder coating and chrome.

CH88 is stackable and stacks up to four chairs.

The chair's dimensions are 44.5 cm (seat height), 76.5 cm (height), 44.5 cm (depth) and 57 cm (width).

The chairs blend of materials, combined with a minimalist design, results in a light, organic, industrial expression.

The CH88's overall flexibility, coupled with its many variants, makes the chair equally well-suited to multiple environments - from the living room to the hotel restaurant or corporate canteen.

ENVIRONMENTAL INFORMATION

Carl Hansen & Søn and sustainability

People's fascination of the combination of good design and wood, as well as other natural materials, is something that transcends time and fashion. At Carl Hansen & Søn, we believe that this fascination helps to explain the great interest in our furniture, and we take very seriously concerns about the sustainability of the natural resources upon which we depend for our products. That is why we strive every day to improve our production methods, logistics and sales efforts in respect of scarce natural resources.

We buy wood only from sustainably managed forests. All sourced wood meets EUTR 2013 regulations, Danish Forest Legislation and current international certifications. Oak, beech and ash come primarily from Danish forests which are managed according to the principles described in Denmark's National Forest Programme; some of these wood types are also sourced from other similarly managed European forests, or, in the case of walnut and cherry, North American forests.

16th Floor, 202 Centre
202-204 Des Vaux Road West
Hong Kong

+852 5631 0267
ml@carlhansen.com

AMERICA

Carl Hansen & Søn Corp

304 Hudson Street
3rd Floor
New York, NY 10013
USA

Tel: +1 212 242 6736
northamerica@carlhansen.com

Carl Hansen & Søn Showroom Los Angeles

8745 Washington Boulevard
Studio B
Culver City, CA 90232
Tel.: + 1 (310) 842-8656

THE DESIGNER

As a driving force behind 'Danish Modern', Hans J. Wegner helped change the general public's view of furniture in the 1950s and 1960s. His passion for designing chairs, more than 500 of them, is recognized worldwide and reflected in his title 'the Master of the Chair'. He is famous for integrating perfectly executed joints with exquisite shapes and combining them with a constant curiosity for materials and deep respect for wood and its natural characteristics. His designs furnish minimalism with organic and natural softness.

Hans J. Wegner was born in 1914 in Tønder in Southern Denmark, the son of a shoemaker. At the age of 17, he completed his apprenticeship as a cabinetmaker in the workshop of H. F. Stahlberg where his first designs saw the light of day. At the age of twenty he moved to Copenhagen, Denmark, to attend the School of Arts and Crafts, where he studied from 1936-1938 before embarking on a career as an architect.

In 1940, Wegner joined Arne Jacobsen and Erik Møller and began designing furniture for the new City Hall in Aarhus, Denmark's second-largest city. This was also the year when Wegner began working with master cabinetmaker Johannes Hansen, who played a major role in introducing modern design to the Danish public.

Hans J. Wegner opened his own drawing office in 1943. In 1944, he designed the first China Chair in a series inspired by Chinese chairs from the Ming dynasty. One of these chairs, the Wishbone Chair, designed in 1949 and

We use every possible bit of these fine hardwoods in our furniture production. Inevitably, however, there are some scraps, which are then used to produce other products or recycled in district heating plants.

CONTACT INFORMATION

EUROPE

Carl Hansen & Søn A/S

Hylkedamvej 77-79
Bygning 2
DK 5591 Gelsted
Denmark

Tel: +45 66 12 14 04
Fax: +45 65 91 60 04
info@carlhansen.com

Carl Hansen & Søn Flagship Store

Bredgade 21
1260 Copenhagen K
Denmark

Phone: +45 64 47 23 60
retail@carlhansen.dk

Carl Hansen & Søn Showroom Oslo

Drammensveien 130 B9
0277 Oslo
Norway

Contract
+47 926 83 994
mh@carlhansen.dk

Retail
+47 900 77 087
hrs@carlhansen.dk

Carl Hansen & Søn Showroom London

16 Bowling Green Lane
London
EC1R 0BD
United Kingdom

Tel: +44 (0) 20 7632 7587
Mail: ukinfo@carlhansen.com

Carl Hansen & Søn Showroom Milan

Piazza Paolo VI
Via Delio Tessa
20121 Milan
Italy

+39 340 4266636
oc@carlhansen.dk

ASIA/PACIFIC

Carl Hansen & Søn Japan K.K.

2F Hills Aoyama, 3-39-9 Jingumae
Shibuya-ku 150-0001
Tokyo, Japan

Tel: +81 3 5413 6771
Fax: +81 3 5413 6772
info@carlhansen.jp

Carl Hansen & Søn Flagship Store Japan

Aoyama Artworks 1/2F
2-5-10 Jingumae
Shibuya-ku, Tokyo, 150-0001

produced by Carl Hansen & Søn since 1950, went on to become Wegner's most successful design of all time.

Hans J. Wegner is considered one of the most creative and productive Danish furniture designers of all time. He has received several accolades given to designers, including the Lunning Prize in 1951 and The 8th International Design Award in 1997.

He became an honorary member of the Royal Danish Academy for the Fine Arts in 1995, and an honorary doctor of the Royal College of Art in 1997. Almost all of the world's major design museums, from The Museum of Modern Art in New York to Die Neue Sammlung in Munich, feature his furniture in their collections. Hans J. Wegner died in Denmark in January 2007 - at the age of 92.

Carl Hansen & Søn's alliance with Hans J. Wegner began in 1949 and resulted in the production of a wide range of Wegner designs spanning dining chairs, easy chairs, footrests, sofas and coffee tables, dining tables as well as high-end office furniture and children's furniture. Wegner's iconic designs from Carl Hansen & Son include the Shell Chair, Wing Chair and Wishbone Chair.

Experience Wegner's iconic Wishbone Chair

Watch the making of the Wishbone Chair

VARIANTS CHOICES AND DIMENSIONS

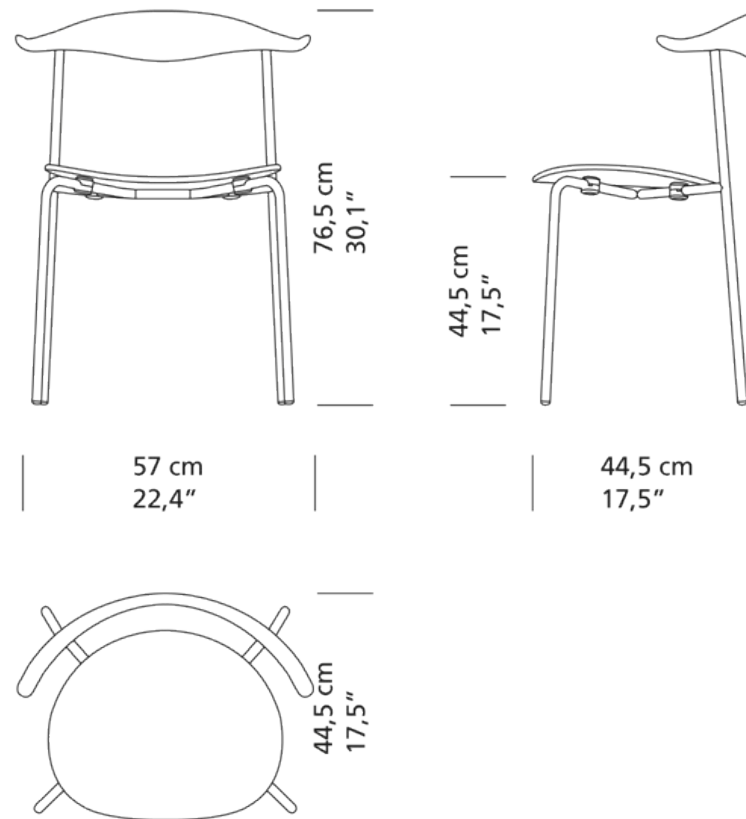

MATERIAL MATRIX

	Soap	Lacquer/Oil	CHS colors	White oil
Beech	●	●	●	
Oak	●	●	●	●
Smoked oak		●		

Oak and ash have a clearly visible wood structure when painted. Beech has minimal structure when painted. Oak is available only in black (NCS S9000-N).

Japan
+81 3 5413 5421

Carl Hansen & Son HK Limited

TESTS AND CERTIFICATIONS

All tests and certificates are available on request.